

de Druckschalter / Druckbegrenzer
 fr Pressostat / Limiteur de pression
 en Pressure controller / Pressure limiter
 it Pressostato / Pressostato di limite
 es Comutador de presión / Limitador de presión
 sv Tryckvakter / Tryckbegränsare
 nl Drukschakelaar / Drukbegrenzer

de Montagevorschrift
 fr Instruction de montage
 en Fitting instructions
 it Istruzioni di montaggio
 es Instrucciones de montaje
 sv Monteringanvisning
 nl Montagevoorschrift

DSB1..F001 DSH1..F001
 DSF1..F001 DSL1..F001



de Installationsanweisung für die Fachkraft
 fr Notice d'installation pour le spécialiste
 en Installation instructions for the technician
 it Informazioni per il personale specializzato
 es Instrucciones para el especialista del ramo
 sv Installationsinstruktion för installatör
 nl Installatietip voor de vakman

de Verschmutzungsgrad III, Überspannung 4000V, Kugeldruckprüfung 100°C, nach EN 60730
 fr Degré de pollution III, surtension 4000V, essai à la bille 100°C selon, EN 60730
 en Pollution degree III, over voltage 4000V, ball pressure test 100°C, as per EN 60730
 it Grado di insudiciamento III, sovratensione 4000V, pressione a sfera 100°C, a norme EN 60730
 es Grado de suciedad III, altatensión 4000V, dureza Brinell 100°C, según EN 60730
 sv Grad av nedsmutsningsgrad III, Överspänning 4000V, kultrycksprovning 100°C, enligt EN 60730
 nl Vervuilinggraad III, Overspanning 4000V, kogeldruktest 100°C, volgens EN 60730

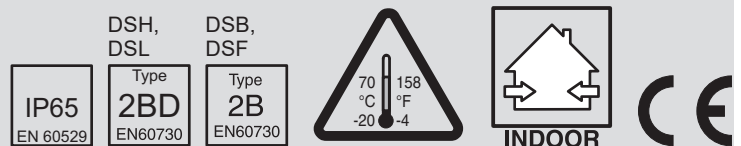
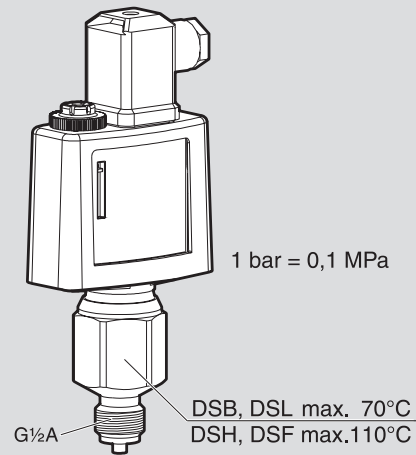

de Bei Verwendung als Sicherheitsapplikation (SIL) muss der Betreiber das Sicherheitshandbuch D100237459 beachten.
 fr Pour une utilisation en tant qu'application de sécurité (SIL), l'exploitant doit tenir compte du manuel de sécurité D100237468.
 en When using this as a safety application (SIL), the operator must adhere to safety manual D100237466.
 it In caso di impiego come applicazione di sicurezza (SIL), l'utente è tenuto a osservare il manuale di sicurezza D100237466.
 es Si se utiliza como aplicación de seguridad (SIL), el explotador de la instalación debe tener en cuenta el manual de seguridad D100237466.
 sv Vid användning som säkerhetsanordning (SIL) måste operatören följa anvisningarna i säkerhetshandboken D100237466.
 nl Bij gebruik als beveiligingstoepassing (SIL) moet de gebruiker het beveiligingshandboek D100237466 in acht nemen.



⚠️ WARNUNG

Anlage in Betrieb

► Vor Arbeitsbeginn, Anlage mittels Hauptschalter ausser Betrieb setzten.

⚠️ AVERTISSEMENT

Installation en service

► Avant de commencer toute tâche, mettez l'installation hors service à l'aide de l'interrupteur principal.

⚠️ WARNING

Plant is operating

► Before starting work, switch off the plant using the main switch.

⚠️ AVVERTENZA

Impianto in funzione

► Prima di iniziare i lavori, mettere fuori servizio l'impianto mediante l'interruttore generale.

⚠️ ADVERTENCIA

Instalación en funcionamiento

► Antes de empezar a trabajar, desconecte la instalación con el interruptor principal.

⚠️ VARNING

Anläggning i drift

► Stäng av anläggningen med huvudströmbrytaren innan arbetet påbörjas.

⚠️ WAARSCHUWING

Installatie in bedrijf

► Voor het begin van de werkzaamheden de installatie met de hoofdschakelaar buiten werking stellen.



⚠ GEFAHR **Verbrennungsgefahr durch heiße Oberflächen**
 ▶ Bei einer Mediumtemperatur von > 80 °C am Druckfühler, besteht Verbrennungsgefahr. Kein Kontakt mit heißen Oberflächen.

⚠ DANGER **Risque de brûlure dû aux surfaces chaudes**
 ▶ Si la température du fluide est > 80 °C au niveau du capteur de pression, il y a risque de brûlure. Ne pas toucher les surfaces chaudes.

⚠ DANGER **Danger of burns due to hot surfaces**
 ▶ At a media temperature of > 80 °C at the pressure sensor, there is danger of burning. Do not touch hot surfaces.

⚠ PERICOLO **Pericolo di ustioni dovuto a superfici calde**
 ▶ Se sul pressostato la temperatura del fluido è > 80 °C, sussiste pericolo di ustioni. Evitare il contatto con le superfici calde.

⚠ PELIGRO **Riesgo de quemaduras por superficies calientes**
 ▶ A partir de una temperatura del medio > 80 °C en la sonda de presión, existe el riesgo de sufrir quemaduras. Evite el contacto con superficies calientes.

⚠ FARA **Heta ytor utgör en risk för brännskador**
 ▶ Om mediets temperatur är > 80 °C vid tryckgivaren föreligger risk för brännskador. Vidrör inte heta ytor

⚠ GEVAAR **Verbrandingsgevaar door hete oppervlakken**
 ▶ Bij een mediumtemperatuur van > 80 °C aan de drukopnemer bestaat verbrandingsgevaar. Geen contact met hete oppervlakken

1

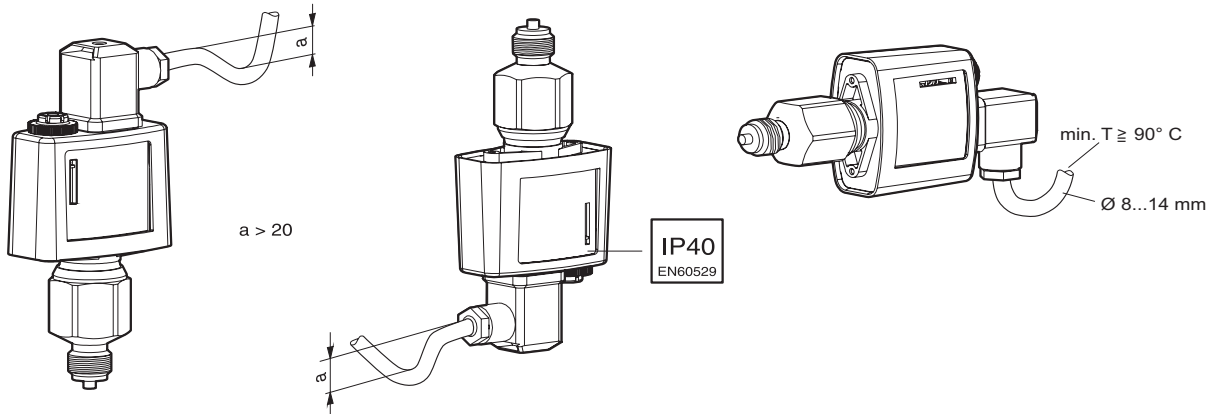

2

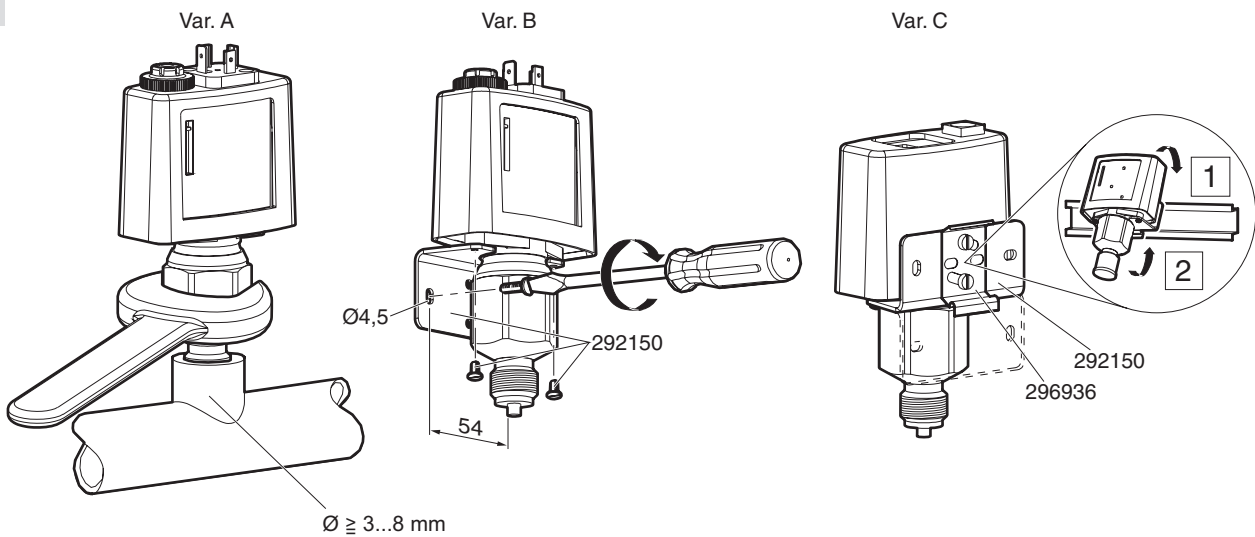

3

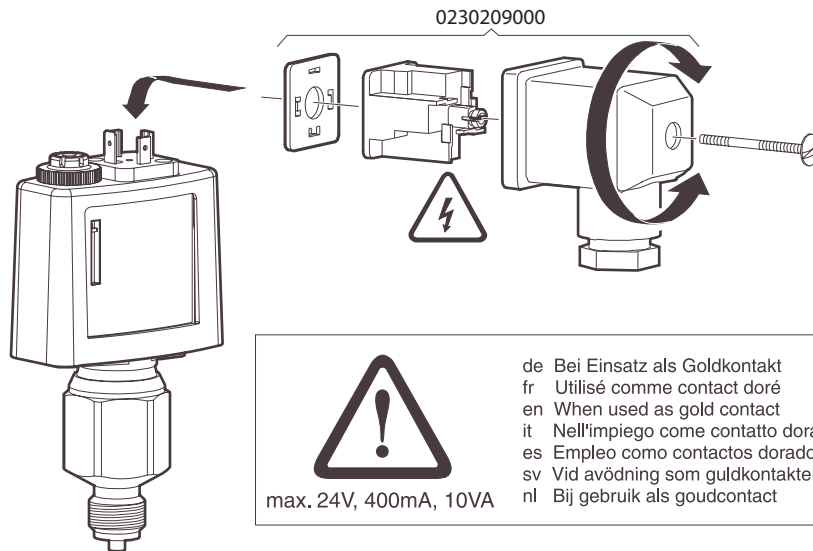

DSB .. / DSF ..

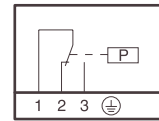

DSH .. / DSL ..

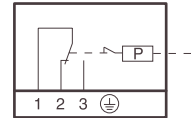

max. 24V, 400mA, 10VA

de Bei Einsatz als Goldkontakt
 fr Utilisé comme contact doré
 en When used as gold contact
 it Nell'impiego come contatto dorato
 es Empleo como contactos dorados
 sv Vid avödnig som guldkontakter
 nl Bij gebruik als goudcontact

4



DSB, DSF
 DWFS (SDBFS)

de Wächter als Sicherheitsdruckbegrenzer
 fr Contôleur comme limiteur de pression de sécurité
 en Pressure monitor as a safety pressure limiter
 it Pressostato come pressostati di limite
 es Controlador como limitador de presión de seguridad
 sv Tryckvakt som används som säkerhetstryckvakt
 nl Drukschakelaar als druckbegrenzingsschakelaar

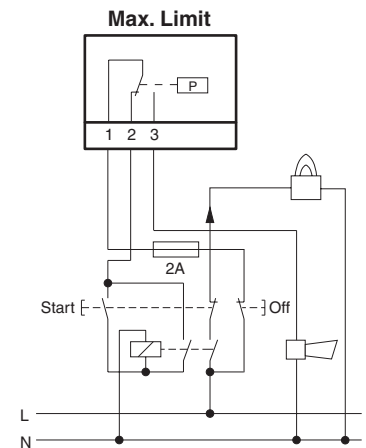
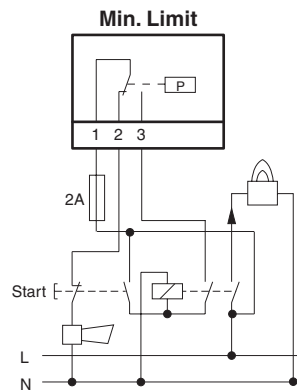

5.1

Xs (DSB, DSF, DSH, DSL)

Reset (DSH/DSL)

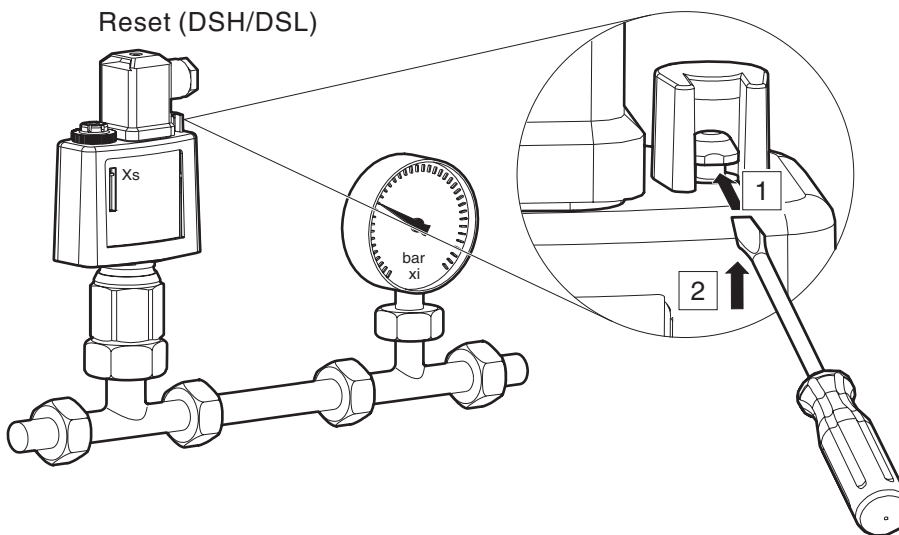

Max. Limit	Reset bei/ if/ si
DSH127	$xi < (Xs - 0.4)$
DSH143	$xi < (Xs - 0.45)$
DSH146	$xi < (Xs - 0.8)$
DSH152	$xi < (Xs - 1.5)$
DSH158	$xi < (Xs - 1.8)$
DSH170	$xi < (Xs - 2)$

Min. Limit	Reset bei/ if/ si
DSL140	$xi > (Xs + 0.4)$
DSL143	$xi > (Xs + 0.5)$
DSL152	$xi > (Xs + 1.2)$

5.2

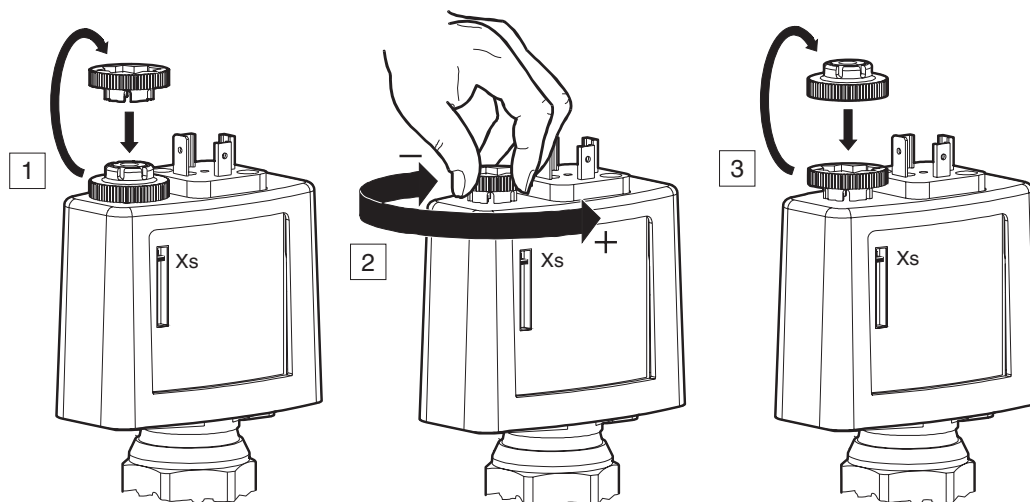

B08346

de Einstellung ausserhalb des Bereichs gemäss Katalog ist nicht zulässig.
 fr L'ajustage en dehors du domaine défini dans le catalogue n'est pas autorisé.
 en Settings outside the range stated in the catalogue are not permissible.
 it Regolazione al difuori del campo indicato in catalogo non ammissibile.
 es No se permiten ajustes fuera del rango indicado en el catálogo.
 sv Inställning utanför området som är angivet i katalogen är ej tillämpligt.
 nl Het instellen van een waarde buiten het bereik zoals in de catalogus vermeld is niet toegestaan.

6a

Xsd (DSB, DSF)

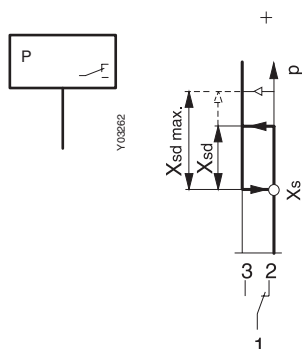

B12685

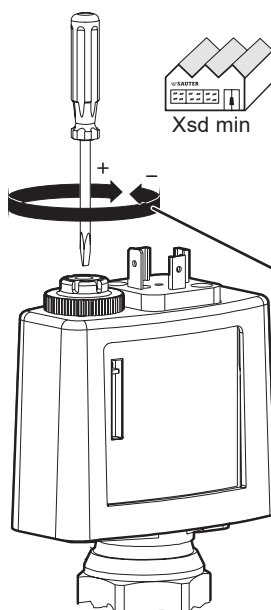
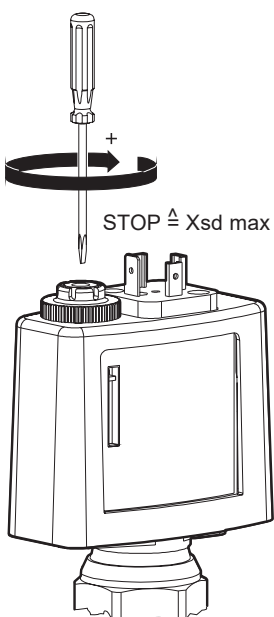

B08347b

Typ	~ Xsd [bar]	
	min.	max.
DSB138	0.25	0.65
DSB140	0.25	0.75
DSB143	0.3	1.6
DSB146	0.8	3.7
DSB152	1.0	4.0
DSB158	1.0	7.5
DSB170	1.4	7.5
DSF125	0.25	0.75
DSF127	0.3	1.5
DSF135	0.12	0.6
DSF138	0.25	0.7
DSF140	0.25	0.75
DSF143	0.3	1.5
DSF146	0.8	3.0
DSF152	1.2	3.8
DSF158	1.5	8
DSF170	1.7	8.2

$\Delta Xsd = Xsd \text{ max.} - Xsd \text{ min.}$

- 1 ○ = 1/5 ΔXsd
- 2 ○ = 2/5 ΔXsd
- 3 ○ = 3/5 ΔXsd
- 4 ○ = 4/5 ΔXsd
- > 5 ○ = ΔXsd min.

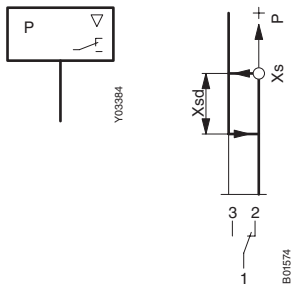
6b Xsd (DSH)

Typ	~ Xsd [bar]
DSH127	- 0.4
DSH143	- 0.45
DSH146	- 0.80
DSH152	- 1.5
DSH158	- 1.8
DSH170	- 2.0

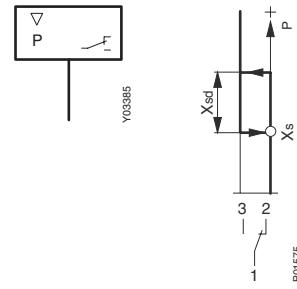
6c Xsd (DSL)

Typ	~ Xsd [bar]
DSL140	+ 0.4
DSL143	+ 0.5
DSL152	+ 1.2



de Zertifikate | fr Certificats | en Certificates | it Certificati | es Certificados | sv Certifikat | nl Certificaten



1) www.certipedia.com

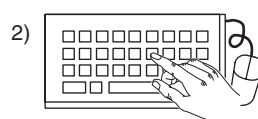

2) SAUTER

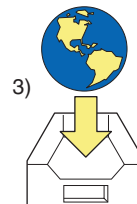

3)



4)



de Weitere Zertifikate
fr Autres certificats
en Additional certificates
it Ulteriori certificati
es Otros certificados
sv Ytterligare certifikat
nl Verdere certificaten

Germanischer Lloyd



Lloyd's Register



www.sauter-controls.com

de 1. Dieses Dokument ist aufzubewahren.
2. Eine regelmässige Überprüfung der Gerätefunktion ist durchzuführen.
3. Sollte bei Ausfall des Gerätes ein Schaden entstehen, so sind weitere Schutzmassnahmen vorzusehen.

fr 1. Ce document est à conserver.
2. Les fonctions de l'appareil sont à vérifier régulièrement.
3. En cas d'un dommage suite à une panne de l'appareil, prévoir des mesures de sécurité supplémentaires.

en 1. Please keep this document.
2. The equipment should be checked regularly to see if it operates properly.
3. If damage is caused as a consequence of this equipment malfunctioning, further protective measures should be taken.

it 1. Il presente documento deve essere conservato.
2. Deve essere eseguito un regolare controllo della funzione dell'apparecchio.
3. Se un fuori servizio dell'apparecchio possa provocare danneggiamenti si debbono prevedere ulteriori misure di protezione.

es 1. Conservar este documento.
2. El equipo debe revisarse regularmente para ver si funciona correctamente.
3. Si la causa de la avería es a consecuencia del mal funcionamiento del equipo, se deberán tomar medidas preventivas adicionales.

sv 1. Detta dokument skall sparas.
2. Apparaten skall regelbundet kontrolleras på sin funktion.
3. Om skada skulle uppstå, då apparaten gått sönder, skall ytterligare skyddsåtgärder vidtagas.

nl 1. Dit document moet worden bewaard.
2. De functie van dit apparaat moet regelmatig worden gecontroleerd.
3. Indien door uitval van het apparaat schade kan ontstaan, dan moeten aanvullende beschermende maatregelen vooraf worden getroffen.

de Dokument aufbewahren
fr Ce document est à conserver
en Retain this document
it Conservare il documento
es Guardar el documento
sv Spara dokumentationen
nl Document bewaren

© Fr. Sauter AG
Im Surinam 55
CH-4058 Basel
Tel. +41 61 - 695 55 55
Fax +41 61 - 695 55 10
www.sauter-controls.com
info@sauter-controls.com

UK Importer:

Sauter (GB)
Inova House
RG24 8GG