

BUT: 3-way unit valve, PN 16 (el.)

How energy efficiency is improved

Linear mixture without loss through leakage in the control passage for energy-efficient control

Features

- Regulation of fan coil units, air secondary-treatment units, heating zones and two-pipe systems with heat exchanger in combination with AXF 217S, AXM 217(S), AXS 315S and AXT 301 actuators for unit valves
- Flat-sealing standard version
- Special model for fan coil units with cast-on bypass T-piece
- Control passage closed when spindle is pushed in
- Used as a control valve
- Valve with male thread as per DIN EN ISO 228-1, class B
- Valve body made of cast brass
- Stainless-steel spindle
- Plug with soft seal made of EPDM for control passage and mixing passage
- Stuffing box with O-ring seal
- Water quality as per VDI 2035

Technical data

Parameters		
Nominal pressure		PN 16
Operating pressure		Max. 16 bar (up to 120 °C)
Operating temperature		2...120 °C
Control passage valve characteristic		Almost linear
Mixing passage valve characteristic		Linear (not reduced)
Leakage rate of control passage A-AB		0.0001% of K_{VS}
Leakage rate of mixing passage B-AB		Approx. 0.1% of K_{VS}

Ambient conditions		
Operating temperature at valve		Max. 100 °C in combination with AXF 217S, AXM 217(S), AXS 315S and AXT 301

Standards, directives		
Pressure and temperature data		EN 764, EN 1333
Flow parameter		VDI/VDE 2173
PED 2014/68/EU		Fluid group II, No CE label (article 4.3)

Overview of types

i The BUT control valve must not be used as a through valve or diverting valve; the mixing passage is not reduced.

Type	Nominal diameter	Valve stroke	K_{VS} value	Connection	Weight
BUT010F200	DN 10	3 mm	1 m ³ /h	G½ B	0.3 kg
BUT010F400	DN 10	3 mm	1.6 m ³ /h	G½ B	0.38 kg
BUT010F410	DN 10	3 mm	1 m ³ /h	G½ B	0.38 kg
BUT010F420	DN 10	3 mm	0.63 m ³ /h	G½ B	0.38 kg
BUT015F210	DN 15	3 mm	2.5 m ³ /h	G¾ B	0.33 kg
BUT015F410	DN 15	3 mm	2.5 m ³ /h	G¾ B	0.42 kg
BUT015F400	DN 15	4 mm	3.5 m ³ /h	G¾ B	0.42 kg
BUT020F200	DN 20	4 mm	4.5 m ³ /h	G1 B	0.36 kg
BUT020F400	DN 20	4 mm	4.5 m ³ /h	G1 B	0.5 kg



BUT010F200



BUT015F400

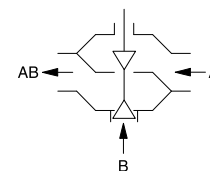

ValveDim app



 BUT0**F4**: Version with bypass T-piece

Accessories

Type	Description
0378133010	Threaded sleeve, R $\frac{3}{8}$, flat-sealing, with cap nut and flat seal, G $\frac{1}{2}$ - R $\frac{3}{8}$
0378133015	Threaded sleeve, R $\frac{1}{2}$, flat-sealing, with cap nut and flat seal, G $\frac{3}{4}$ - R $\frac{1}{2}$
0378133020	Threaded sleeve, R $\frac{3}{4}$, flat-sealing, with cap nut and flat seal, G1 - R $\frac{3}{4}$
0378134010	Solder nipple, Ø 12, flat-sealing, with cap nut and flat seal, G $\frac{1}{2}$
0378134015	Solder nipple, Ø 15, flat-sealing, with cap nut and flat seal, G $\frac{3}{4}$
0378134020	Solder nipple, Ø 22, flat-sealing, with cap nut and flat seal, G1
0378145015	Clamping ring screw fitting for pipe Ø 15 mm, DN 15, flat-sealing, G $\frac{3}{4}$
0378145020	Clamping ring screw fitting for pipe Ø 22 mm, DN 20, flat-sealing, G1

Combination of BUT with electric actuators

- i Warranty:** The technical data and pressure differences indicated here are applicable only in combination with SAUTER valve actuators. Any warranty will be invalidated if used with valve actuators from other manufacturers.
- i Definition of Δp_s :** Maximum admissible pressure drop in the event of a malfunction (pipe break after the valve) at which the actuator reliably closes the valve.
- i Definition of Δp_{max} :** Maximum admissible pressure drop in control mode at which the actuator reliably opens and closes the valve. Data for a static pressure of 6 bar.
- i Definition of close/off pressure:** Max. admissible differential pressure when closing the valve. Calculation, see below.

Pressure differences with motorised actuators

Actuator	AXF217SF404 AXF217SF405 AXM217SF402 AXM217SF404	AXM217F200	AXM217F202
Voltage	24 VAC/DC	230 VAC	24 VAC/DC
Control signal	0/2...10 V, 0...5 V, 5...10 V, 0/4...20 mA	2-/3-point	2-/3-point
Laufzeit	8 s/mm	13 s/mm	13 s/mm
As control valve	Δp_{max} [bar]	Δp_{max} [bar]	Δp_{max} [bar]
BUT010F200 BUT010F400 BUT010F410 BUT010F420	1.7	1.7	1.7
BUT015F210 BUT015F410	1.4	1.4	1.4
BUT015F400	1.2	1.2	1.2
BUT020F200 BUT020F400	1.0	1.0	1.0

Cannot be used as distribution valve

 Close/off pressure = $\Delta p_{max} + 0.1 \text{ bar}$

Pressure differences with thermal actuators

Actuator	AXT301F100 AXT301F110	AXT301F102 AXT301F112	AXT301F210	AXT301F212	AXT301HF110	AXT301HF112
Voltage	230 VAC	24 VAC/DC	230 VAC	24 VAC/DC	230 VAC	24 VAC/DC
Control signal	2-point	2-point	2-point	2-point	2-point	2-point
Laufzeit	48 s/mm	48 s/mm	48 s/mm	48 s/mm	52 s/mm	52 s/mm
As control valve	Δp_{max} [bar]	Δp_{max} [bar]	Δp_{max} [bar]	Δp_{max} [bar]	Δp_{max} [bar]	Δp_{max} [bar]
BUT010F200 BUT010F400 BUT010F410 BUT010F420	1.5	1.5	1.5	1.5	1.5	1.5
	Δp_s [bar]	Δp_s [bar]	Δp_s [bar]	Δp_s [bar]	Δp_s [bar]	Δp_s [bar]
	1.8	1.8	1.8	1.8	1.8	1.8

Actuator	AXT301F100 AXT301F110		AXT301F102 AXT301F112		AXT301F210	AXT301F212	AXT301HF110		AXT301HF112	
BUT015F210 BUT015F410	1.2	1.5	1.2	1.5	1.2	1.2	1.2	1.5	1.2	1.5
BUT015F400	1.0	1.3	1.0	1.3	1.0	1.0	1.0	1.3	1.0	1.3
BUT020F200 BUT020F400	0.9	1.1	0.9	1.1	0.9	0.9	0.9	1.1	0.9	1.1

Cannot be used as distribution valve

☛ Close/off pressure = $\Delta p_{max} + 0.3 \text{ bar}$

Pressure differences with thermal continuous actuators

Actuator	AXS315SF102		AXS315SF202
Voltage	24 VAC/DC		24 VAC/DC
Control signal	0...10 V		0...10 V
Laufzeit	30 s/mm		30 s/mm
As control valve	Δp_{max} [bar]	Δp_s [bar]	Δp_{max} [bar]
BUT010F200 BUT010F400 BUT010F410 BUT010F420	1.7	1.8	1.7
BUT015F210 BUT015F410	1.4	1.5	1.4
BUT015F400	1.2	1.3	1.2
BUT020F200 BUT020F400	1.0	1.1	1.0

Cannot be used as distribution valve

☛ Close/off pressure = $\Delta p_{max} + 0.1 \text{ bar}$

Description of operation

The BUT 3-way valve can be moved to any intermediate position with a thermal or motorised actuator. When the spindle is pressed in, the control passage (passage A–AB) is closed and the mixing passage B–AB is open. It is reset by spring force in the valve.

Used as a control valve

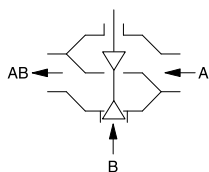

The valve is used as a control valve in heating and cooling circuits of HVAC installations and may only be used for these purposes. The direction of flow is marked on the valve.

The valve can be moved to the open or closed positions with the thermal actuator for unit valves AXT 301. In combination with the NC (normally closed) version of the actuator, the control passage of the valve closes in the event of a power failure.

The valve can be moved to any position with the AXS 315S continuous actuator for unit valves. The positioner integrated in the actuator controls the actuator depending on positioning signal y.

The valve can be moved to any position with the AXM 217 motorised actuator for unit valves. With the AXF 217S and AXM 217S types (with positioner), the valve is continuously adjusted with a 0...10 V or 4...20 mA control signal.

Intended use

This product is only allowed to be used in HVAC building systems for control and regulation purposes. Other uses require the prior consent of the manufacturer.

The section "Description of operation" and all product instructions in this data sheet must be observed.

Modifying or converting the product is not permitted.

Improper use

The product is not suitable for:

- Safety applications
- Drinking water installations



Notice in accordance with California Proposition 65

The product contains lead. To be marketed in North America, the appropriate warnings must be affixed to the product or packaging.

Engineering and fitting notes

The valve may only be insulated up to the level of the cap nut or bayonet ring of the actuator.

The stuffing box may only be replaced when the valve is not pressurised. The stuffing box is sealed against the medium.

Fitting position

Do not install the valve in a suspended position. The control unit could be damaged by the ingress of condensate or dripping water.

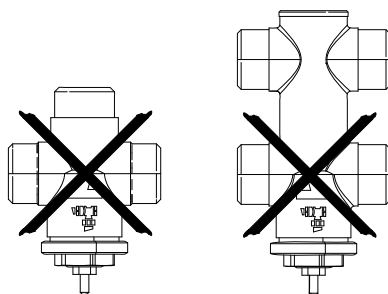

Using with water

To increase the functional reliability of the valve, the system should conform to DIN EN 14336 (heating systems in buildings). The standard states, amongst other things, that the system has to be flushed through before being put into service.

So that impurities are retained in the water (e.g. weld beads, rust particles, etc.) and the spindle seal is not damaged, we recommend installing collecting filters, for example one for each floor or pipe run. Requirements for water quality as per VDI 2035.

When using an additive in the water, the compatibility of the valve materials must be checked with the manufacturer of the medium. The materials table shown below may be used. When glycol is used, the recommended concentration is between 16% and 40%.

Hydraulics and noise in plants

The valve can be used in a low-noise environment. To prevent flow noise, the pressure difference Δp_{\max} across the valve should not exceed 0.5 bar.

Flow-rate chart

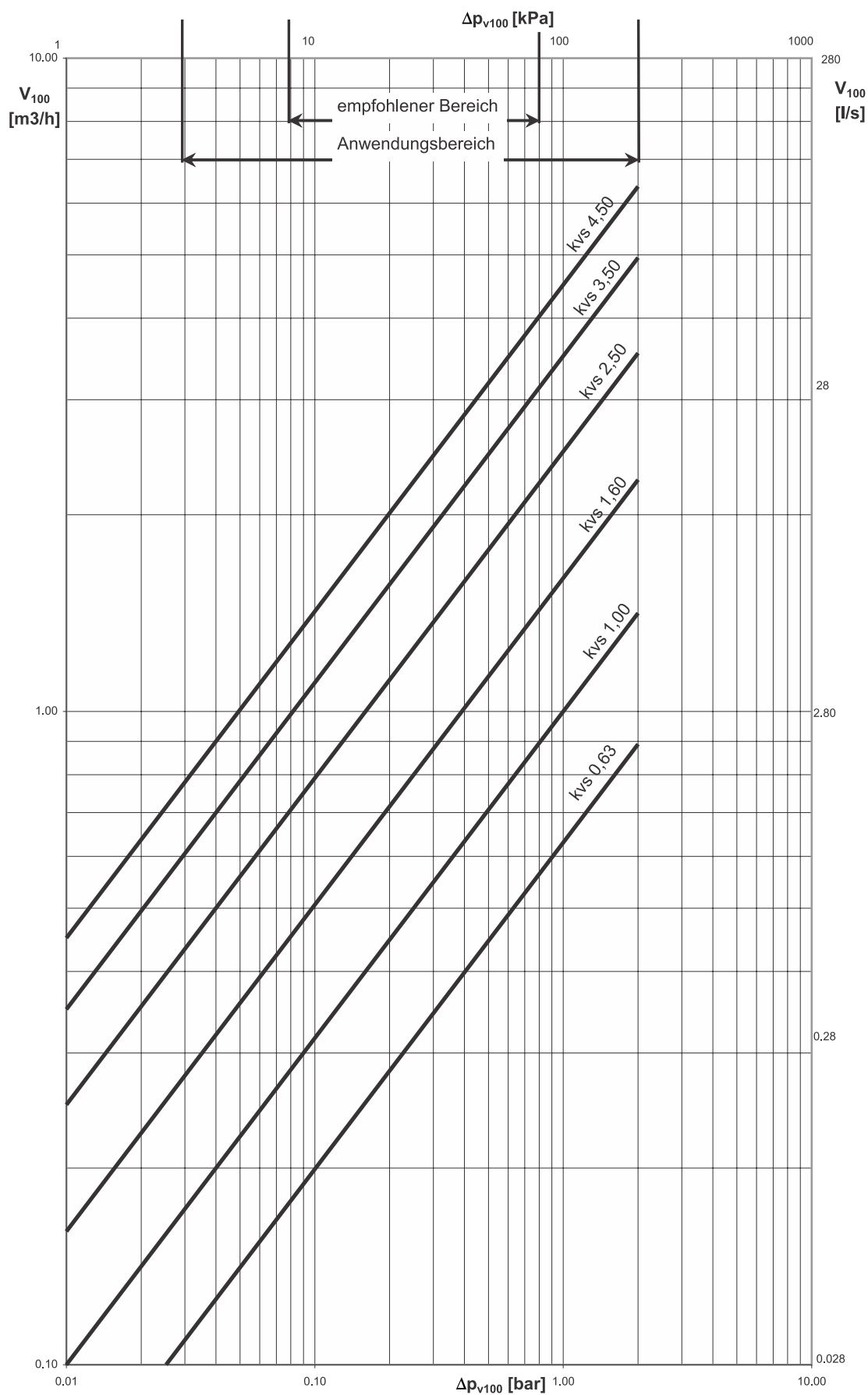

B12268

Additional information

	Document no.
Fitting instructions for BUT	P100007308
Fitting instructions for AXF 217S	P100019389
Fitting instructions for AXM 217/217S	P100011418
Fitting instructions for AXS 315S	P100019937
Fitting instructions for AXT 301	P100019922
SAUTER slide rule for valve sizing	P100013496
Manual for SAUTER slide rule	7000129001
Declaration on materials and the environment	MD 55.109

Valve design



SAUTER provides various tools for valve design and engineering:

- ValveDim smartphone app
- ValveDim PC program
- ValveDim slide rule

You can find the tools under the link www.sauter-controls.com/en/performance/valve-calculation/ or scan the QR code



Design and materials

Valve body made of moulded brass with male thread as per ISO 228/1, class B, flat seal on housing. Stuffing box with ethylene-propylene O-ring. No protective cap or manual adjustment knob; spindle is protected by the packaging.

Material numbers as per DIN

	DIN/EN material no.	DIN/EN designation
Valve body	CW617N	CuZn40Pb2 as per EN 12164
Valve seat	CW617N	CuZn40Pb2 as per EN 12164
Spindle	1.4310	X10CrNi18-8 as per EN 10088-1
Plug	CW617N	CuZn40Pb2 as per EN 12164
Stuffing box	CW617N	CuZn40Pb2 as per EN 12164

Definition of pressure differences

- Δp_v :** Maximum admissible pressure difference over the valve at every stroke position, limited by noise level and erosion. With this parameter, the valve is characterised as a flow element with specific hydraulic behaviour. Monitoring the cavitation and erosion along with the associated noise increases both the service life and the operational capacity.
- Δp_{max} :** Maximum admissible pressure difference over the valve at which the actuator can reliably open and close the valve. The following are considered: Static pressure and flow effects. This value ensures trouble-free stroke movement and tightness. The value Δp_v of the valve is never exceeded.
- Δp_s :** Maximum admissible pressure difference over the valve in the event of a malfunction (e.g. power failure, excessive temperature or pressure, pipe break) at which the actuator can close the valve tightly and, if necessary, maintain the entire operating pressure against atmospheric pressure. Because this is a safety function with a rapid stroke movement, Δp_s can be greater than Δp_{max} or Δp_v . The flow disturbing effects that arise here are quickly passed through. They are of secondary importance with this method of operation. For 3-way valves, the values only apply to the control passage.
- Δp_{stat} :** Line pressure behind the valve. This essentially corresponds to the idle pressure when the pump is switched off, caused for example by the fluid level in the system, increased pressure due to pressure tanks or steam pressure. For valves that close with pressure, the static pressure plus the pump pressure are used.

Disposal

When disposing of the product, observe the currently applicable local laws.
 More information on materials can be found in the Declaration on materials and the environment for this product.

Dimension drawings

All dimensions in mm.

BUT0**F2*0

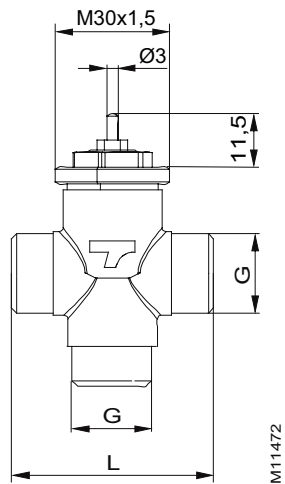

BUT0**F4*0

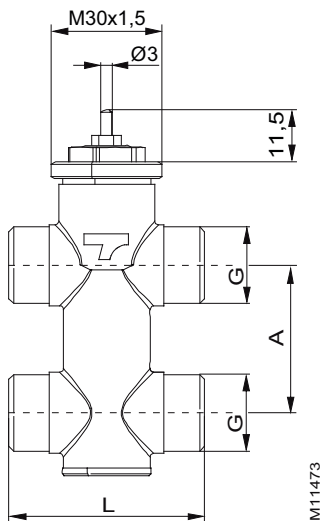

Type	A	L	G (inch)
BUT010F200	-	52	G½ B
BUT010F400	40		
BUT010F410			
BUT010F420			
BUT015F210	-	56	G¾ B
BUT015F400	40		
BUT015F410			
BUT020F200	-	65	G1 B
BUT020F400	50		

Combinations

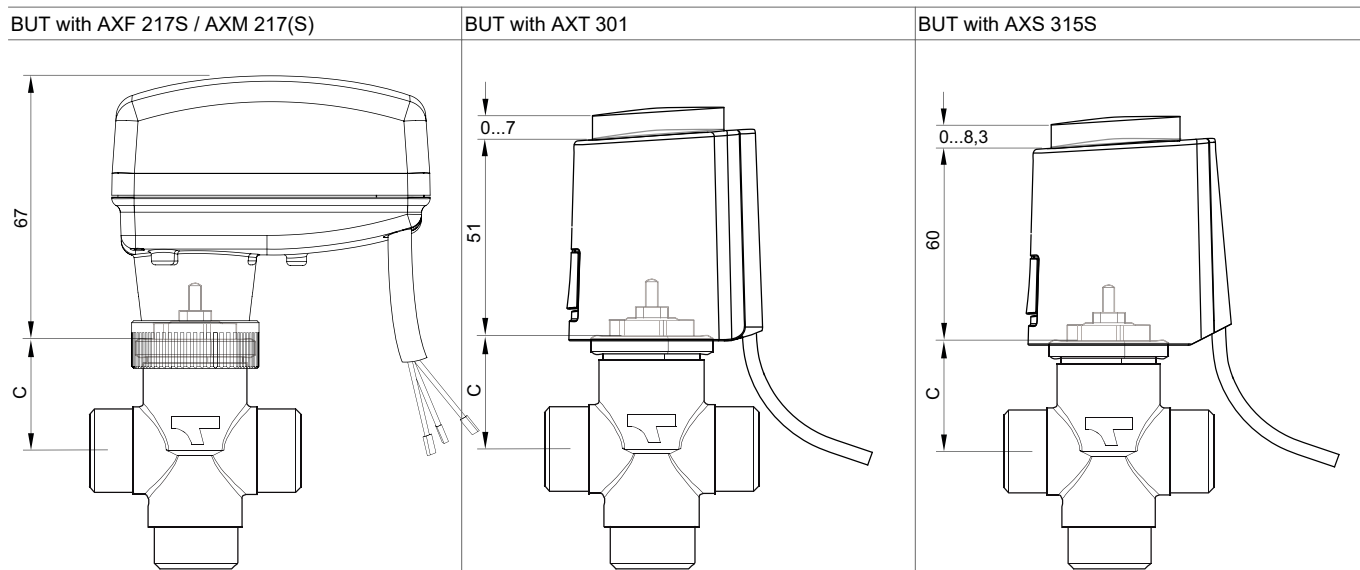

Type	C
BUT010F200	29.2
BUT015F210	29.2
BUT020F200	30.2
BUT010F4*0	29.2
BUT015F4*0	30.2
BUT020F4*0	30.2

Accessories

Threaded sleeve 03781330**

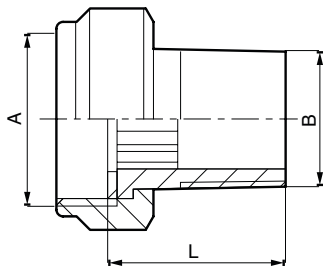

DN	A	B	L
10	G1/2	R3/8	24
15	G3/4	R1/2	27,5
20	G1	R3/4	32,5

Solder nipple 03781340**

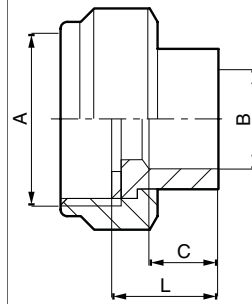

DN	A	B	C	L
10	G1/2	12	8,6	14
15	G3/4	15	10,6	15,5
20	G1	22	15,4	20

Clamping ring screw fitting 03781450**

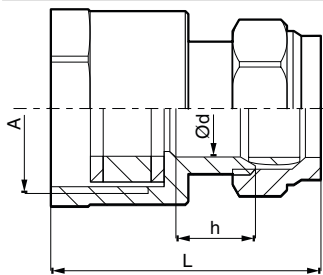

DN	A	L	Ød	h
15	G3/4	39,5	15,2	12,5
20	G1	41,5	22,2	16